

1. Description

The ES1227 is a Latch Hall effect sensor IC fabricated from BiCMOS technology. The device integrates a voltage regulator, Hall sensor with dynamic offset cancellation system, Schmitt trigger and an open-drain output driver with over-current protection, all in a single package.

It incorporates advanced chopper stabilization techniques to provide accurate and stable magnetic switch points. There are many applications for this sensor in addition to those listed above. The design, specifications and performance have been optimized for commutation applications in 5V to 12V brushless DC motors.

Thanks to its wide operating voltage range and extended choice of temperature range, it is quite suitable for use in automotive, industrial and consumer applications.

The device is delivered in a Small Outline Transistor (SOT) for surface mount process and in a Plastic Single In Line (TO-92 flat) for through-hole mount. Both 3-lead packages are RoHS compliant.

2. Product Image

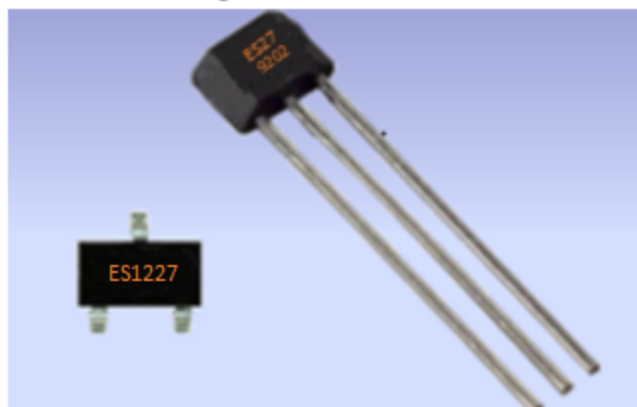

3. Features

- ◆ AEC-Q100 automotive qualified
- ◆ Operating voltage range from 2.8V to 24V
- ◆ magnetic sensitivity – +/-75GS
- ◆ BiCMOS technology
- ◆ -30V Reversed Power Supply Protection
- ◆ -40°C~150°C Operating Temperature
- ◆ Output Limiting Current Protection
- ◆ Open drain output
- ◆ ESD 7KV
- ◆ RoHS Compliant: (EU)2015/863

4. Applications

- ◆ Automotive, Consumer and Industrial
- ◆ Solid-state switch
- ◆ Brushless DC motor commutation
- ◆ Speed detection
- ◆ Linear position detection
- ◆ Angular position detection
- ◆ Proximity detection

5. Functional Block Diagrams

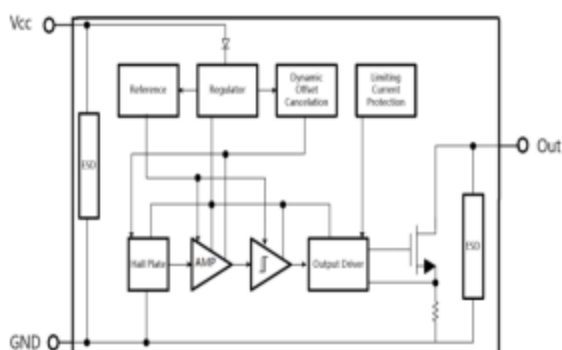

6. Pin Definitions and Descriptions

SO Pin No.	UA Pin No.	Name	Type	Function
1	1	V _{DD}	Supply	Supply Voltage Pin
2	3	OUT	Output	Open Drain Output Pin
3	2	GND	Ground	Ground Pin



7. Detailed General Description

The ES1227 exhibits latch magnetic switching characteristics. Therefore, it requires both south and north poles to operate properly.

The OUT pin of these devices switches low (turns on) when a magnetic field perpendicular to the Hall sensor exceeds the operate point threshold, B_{OP}. After turn-on, the output voltage is V_{DSon}. Note that the device latches, that is, a south pole of sufficient strength towards the branded surface of the device turns the

device on. The device remains on if the south pole is removed ($B \rightarrow 0$). This latching property defines the device as a magnetic memory.

When the magnetic field is reduced below the release point, B_{RP} , the OUT pin turns off (goes high). The difference in the magnetic operate and release points is the hysteresis, B_{HYS} , of the device. This built-in hysteresis prevents output oscillation near the switching point, and allows clean switching of the output even in the presence of external mechanical vibration and electrical noise.

The device behaves as a latch with symmetric operating and release switching points ($B_{OP} = |B_{RP}|$). This means magnetic fields with equivalent strength and opposite direction drive the output high and low.

Powering-on the device in the hysteresis region (less than B_{OP} and higher than B_{RP}) allows an indeterminate output state. The correct state is attained after the first excursion beyond B_{OP} or B_{RP} .

The SOT-23 device is reversed from the UA package. The SOT-23 output transistor will be latched on in the presence of a sufficiently strong North pole magnetic field applied to the marked face.

8. Unique Features

Based on BiCMOS technology, InnoSen ES1227 is a Hall-effect device with precise magnetic sensitivity. This multi-purpose latch suits most of the application requirements.

The chopper-stabilized amplifier uses switched capacitor technique to suppress the offset generally observed with Hall sensors and amplifiers. The CMOS technology makes this advanced technique possible and contributes to smaller chip size and lower current consumption than bipolar technology. The small chip size is also an important factor to minimize the effect of physical stress. This combination results in more stable magnetic characteristics and enables faster and more precise design.

The operating voltage from 2.8V to 24V, low current consumption and large choice of operating temperature range according to "L", and "E" specification make this device suitable for automotive, industrial and consumer applications.

9. Absolute Maximum Ratings

Note: Exceeding the absolute maximum ratings may cause permanent damage. Exposure to absolute-maximum-rated conditions for extended periods may affect device reliability.